

内径10~40mm

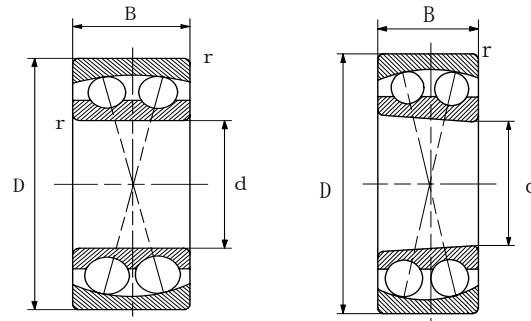
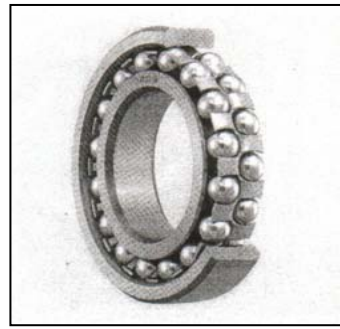

円筒穴

テーパ穴
テーパ 1:12

主要寸法(mm) Dimensions				呼び番号		許容回転数(rpm)		基本定格荷重(kN)		重量
内径 d	外径 D	厚み B	面取り r	円筒穴 Cylindrical	テーパ穴 Tapered	グリス潤滑 Grease	油潤滑 Oil	動荷重 Dyn(Cr)	静荷重 Sta(Cor)	(kg) Weight
10	30	9	0.6	1200	1200K	15000	19000	4.22	1.32	0.035
	30	14	0.6	2200	-	15000	19000	5.48	1.72	0.050
	35	11	0.6	1300	1300K	14000	18000	5.55	1.82	0.060
	35	17	0.6	2300	-	14000	18000	8.48	2.50	0.090
12	32	10	0.6	1201	1201K	14000	18000	4.28	1.48	0.042
	32	14	0.6	2201	-	14000	18000	5.68	1.95	0.060
	37	12	1.0	1301	1301K	13000	17000	7.25	2.35	0.070
	37	17	1.0	2301	-	13000	17000	8.85	2.80	0.100
15	35	11	0.6	1202	1202K	13000	17000	5.75	2.02	0.051
	35	14	0.6	2202	2202K	13000	17000	5.88	2.15	0.060
	42	13	1.0	1302	1302K	12000	16000	7.30	2.65	0.100
	42	17	1.0	2302	-	12000	16000	9.22	3.25	0.110
17	40	12	0.6	1203	1203K	12000	16000	6.08	2.40	0.076
	40	16	0.6	2203	2203K	12000	16000	6.92	2.75	0.090
	47	14	1.0	1303	1303K	11000	15000	9.06	3.68	0.140
	47	19	1.0	2303	-	11000	15000	11.20	4.02	0.170
20	47	14	1.0	1204	1204K	10000	14000	7.65	3.18	0.120
	47	18	1.0	2204	2204K	10000	14000	9.62	3.88	0.150
	52	15	1.1	1304	1304K	9500	13000	9.60	4.02	0.170
	52	21	1.1	2304	2304K	9500	13000	13.8	5.28	0.220
25	52	15	1.0	1205	1205K	9000	12000	9.32	4.02	0.140
	52	18	1.0	2205	2205K	9000	12000	9.62	4.28	0.190
	62	17	1.1	1305	1305K	8000	10000	13.80	5.98	0.260
	62	24	1.1	2305	2305K	8000	10000	18.80	7.45	0.350
30	62	16	1.0	1206	1206K	7500	9500	12.20	5.78	0.230
	62	20	1.0	2206	2206K	7500	9500	11.80	5.68	0.260
	72	19	1.1	1306	1306K	7000	9000	16.50	7.75	0.400
	72	27	1.1	2306	2306K	7000	9000	24.20	10.00	0.500
35	72	17	1.1	1207	1207K	6700	8500	12.20	6.62	0.320
	72	23	1.1	2207	2207K	6700	8500	16.80	8.32	0.440
	80	21	1.5	1307	1307K	6300	8000	19.20	9.80	0.540
	80	31	1.5	2307	2307K	6300	8000	30.20	12.80	0.680
40	80	18	1.1	1208	1208K	6300	8000	14.80	8.52	0.410
	80	23	1.1	2208	2208K	6300	8000	17.20	9.45	0.530
	90	23	1.5	1308	1308K	5600	7000	22.80	12.20	0.710
	90	33	1.5	2308	2308K	5600	7000	34.50	15.80	0.930

内径45~85mm

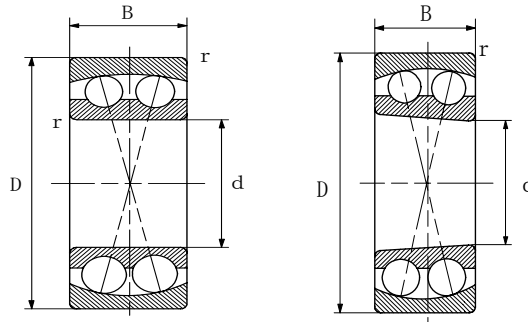

円筒穴

テーパ穴
テーパ 1:12

主要寸法(mm) Dimensions				呼び番号		許容回転数(rpm)		基本定格荷重(kN)		重量
内径 d	外径 D	厚み B	面取り r	円筒穴 Cylindrical	テーパ穴 Tapered	グリス潤滑 Grease	油潤滑 Oil	動荷重 Dyn(Cr)	静荷重 Sta(Cor)	(kg) Weight
45	85	19	1.1	1209	1209K	5600	7000	16.80	9.55	0.490
	85	23	1.1	2209	2209K	5600	7000	17.80	10.80	0.550
	100	25	1.5	1309	1309K	5000	6300	29.20	15.80	0.960
	100	36	1.5	2309	2309K	5000	6300	41.50	19.50	1.250
50	90	20	1.1	1210	1210K	5300	6700	17.50	9.80	0.540
	90	23	1.1	2210	2210K	5300	6700	17.80	11.20	0.680
	110	27	2	1310	1310K	4800	6000	33.20	17.50	1.210
	110	40	2	2310	2310K	4800	6000	49.50	23.50	1.640
55	100	21	1.5	1211	1211K	4800	6000	20.50	13.20	0.720
	100	25	1.5	2211	2211K	4800	6000	20.50	13.20	0.810
	120	29	2	1311	1311K	4300	5300	39.50	22.50	1.580
	120	43	2	2311	2311K	4300	5300	57.80	28.00	2.100
60	110	22	1.5	1212	1212K	4500	5600	23.20	15.50	0.900
	110	28	1.5	2212	2212K	4500	5600	26.20	16.80	1.100
	130	31	2.1	1312	1312K	4000	5000	44.00	26.50	1.960
	130	46	2.1	2312	2312K	4000	5000	66.80	32.80	2.600
65	120	23	1.5	1213	1213K	4000	5000	23.80	17.20	0.920
	120	31	1.5	2213	2213K	4000	5000	33.50	21.50	1.500
	140	33	2.1	1313	1313K	3600	4500	47.50	29.50	2.390
	140	48	2.1	2313	2313K	3600	4500	73.80	38.50	3.200
70	125	24	1.5	1214	1214K	3800	4800	26.50	18.80	1.290
	125	31	1.5	2214	2214K	3800	4800	33.80	22.80	1.620
	150	35	2.1	1314	1314K	3400	4300	57.20	35.20	3.000
	150	51	2.1	2314	2314K	3400	4300	84.20	44.50	3.900
75	130	25	1.5	1215	1215K	3600	4500	29.80	21.50	1.350
	130	31	1.5	2215	2215K	3600	4500	34.00	23.80	1.720
	160	37	2.1	1315	1315K	3200	4000	60.80	38.20	3.600
	160	55	2.1	2315	2315K	3200	4000	94.80	50.80	4.700
80	140	26	2	1216	1216K	3400	4300	30.50	23.50	1.650
	140	33	2	2216	2216K	3400	4300	37.50	26.80	2.190
	170	39	2.1	1316	1316K	3000	3800	68.00	42.20	4.200
	170	58	2.1	2316	2316K	3000	3800	99.00	54.20	5.700
85	150	28	2	1217	1217K	3200	4000	37.50	28.50	2.100
	150	36	2	2217	2217K	3200	4000	44.80	31.50	2.530
	180	41	3	1317	1317K	2800	3600	75.20	48.50	5.000
	180	60	3	2317	2317K	2800	3600	108.0	61.20	6.700

内径90~100mm

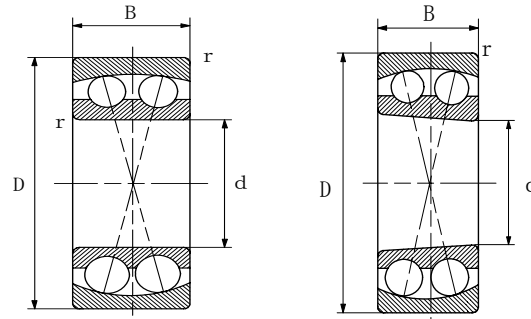
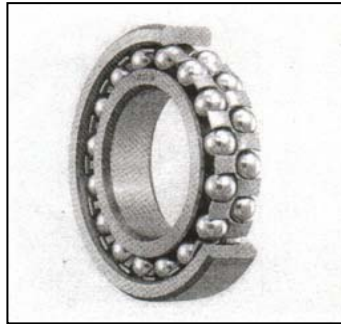

円筒穴

テーパ穴
テーパ 1:12

主要寸法(mm) Dimensions				呼び番号		許容回転数(rpm)		基本定格荷重(kN)		重量 (kg) Weight
内径 d	外径 D	厚み B	面取り r	円筒穴 Cylindrical	テーパ穴 Tapered	グリス潤滑 Grease	油潤滑 Oil	動荷重 Dyn(Cr)	静荷重 Sta(Cor)	
90	160	30	2	1218	1218K	3000	3800	43.50	31.80	2.500
	160	40	2	2218	2218K	3000	3800	53.80	38.00	3.220
	190	43	3	1318	1318K	2600	3400	89.50	56.20	6.000
	190	64	3	2318	2318K	2600	3400	110.00	68.20	7.900
95	170	32	2.1	1219	1219K	2800	3600	48.80	36.00	3.000
	170	43	2.1	2219	2219K	2800	3600	63.80	45.20	4.200
	200	45	3	1319	1319K	2400	3200	102.00	63.80	7.000
	200	67	3	2319	2319K	2400	3200	125.00	76.20	9.200
100	180	34	2.1	1220	1220K	2600	3400	52.80	40.50	3.700
	180	46	2.1	2220	2220K	2600	3400	74.80	53.20	5.000
	215	47	3	1320	1320K	2000	2800	110.00	72.80	8.640
	215	73	3	2320	2320K	2000	2800	148.00	93.50	12.400

内径25~100mm

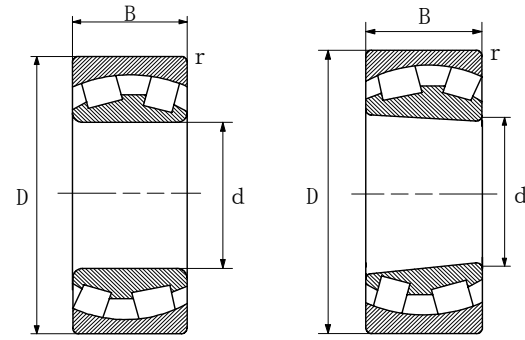

円筒穴

テーパ穴
テーパ 1:12

主要寸法(mm) Dimensions				呼び番号		許容回転数(rpm)		基本定格荷重(kN)		重量
内径 d	外径 D	厚み B	面取り r	円筒穴 Cylindrical	テーパ穴 Tapered	グリス潤滑 Grease	油潤滑 Oil	動荷重 Dyn(Cr)	静荷重 Sta(Cor)	(kg) Weight
25	52	18	1.0	22205	22205K	6000	7500	25.0	18.0	0.178
30	62	20	1.0	22206	22206K	5300	6700	30.0	21.8	0.287
35	72	23	1.1	22207	22207K	4800	6000	44.5	34.0	0.430
40	80	23	1.1	22208	22208K	4500	5600	48.8	39.2	0.550
	90	33	1.5	22308	22308K	4000	5000	72.2	55.5	1.030
45	85	23	1.1	22209	22209K	4000	5000	51.2	41.8	0.590
	100	36	1.5	22309	22309K	3600	4500	105.0	85.8	1.400
50	90	23	1.1	22210	22210K	3800	4800	55.0	45.8	0.870
	110	40	2.0	22310	22310K	3400	4300	125.0	105.0	1.900
55	100	25	1.5	22211	22211K	3400	4300	58.8	49.8	0.881
	120	43	2.0	22311	22311K	3000	3800	152.0	122.0	2.400
60	110	28	1.5	22212	22212K	3200	4000	80.2	70.2	1.220
	130	46	2.1	22312	22312K	2800	3600	165.0	138.0	3.000
65	120	31	1.5	22213	22213K	2800	3600	86.8	73.5	1.630
	140	48	2.1	22313	22313K	2400	3200	185.0	155.0	3.600
70	125	31	1.5	22214	22214K	2600	3400	92.2	81.5	1.660
	150	51	2.1	22314	22314K	2200	3000	225.0	195.0	4.400
75	130	31	1.5	22215	22215K	2400	3200	92.2	81.5	1.750
	160	55	2.1	22315	22315K	2000	2800	258.0	238.0	5.400
80	140	33	2.0	22216	22216K	2200	3000	112.0	102.0	2.200
	170	58	2.1	22316	22316K	1900	2600	282.0	248.0	6.400
85	150	36	2.0	22217	22217K	2000	2800	142.0	130.0	2.800
	180	60	3.0	22317	22317K	1800	2400	302.0	270.0	7.400
90	160	40	2.0	22218	22218K	1900	2600	165.0	155.0	4.000
	190	64	3.0	22318	22318K	1700	2200	358.0	330.0	8.800
95	170	43	2.1	22219	22219K	1800	2400	208.0	185.0	4.200
	200	67	3.0	22319	22319K	1600	2000	378.0	350.0	10.30
100	180	46	2.1	22220	22220K	1700	2200	218.0	205.0	5.000
	215	73	3.0	22320	22320K	1400	1800	442.0	405.0	13.00

内径110~200mm

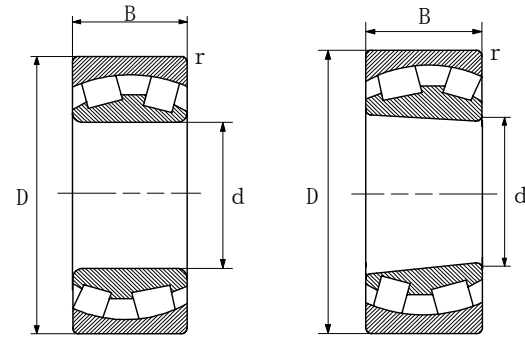

円筒穴

テーパ穴
テーパ 1:12

主要寸法(mm) Dimensions				呼び番号		許容回転数 (rpm)		基本定格荷重 (kN)		重量
内径 d	外径 D	厚み B	面取り r	円筒穴 Cylindrical	テーパ穴 Tapered	グリス潤滑 Grease	油潤滑 Oil	動荷重 Dyn(Cr)	静荷重 Sta(Cor)	(kg) Weight
110	170	45	2.0	23022	23022K	1400	1800	198.0	222.0	3.900
	200	53	2.1	22222	22222K	1500	1900	282.0	268.0	7.400
	240	80	3.0	22322	22322K	1200	1600	535.0	508.0	18.100
120	180	46	2.0	23024	23024K	1200	1600	208.0	252.0	4.300
	215	58	2.1	22224	22224K	1300	1700	335.0	325.0	9.200
	260	86	3.0	22324	22324K	1100	1500	632.0	605.0	22.000
130	200	52	2.0	23026	23026K	1100	1500	265.0	328.0	6.200
	230	64	3.0	22226	22226K	1200	1600	400.0	405.0	11.200
	280	93	4.0	22326	22326K	950	1300	708.0	702.0	29.000
140	210	53	2.0	23028	23028K	950	1300	280.0	342.0	6.700
	250	68	3.0	22228	22228K	1000	1400	468.0	465.0	14.500
	300	102	4.0	22328	22328K	900	1200	808.0	805.0	36.000
150	225	56	2.1	23030	23030K	900	1200	322.0	412.0	8.140
	270	73	3.0	22230	22230K	950	1300	498.0	500.0	18.500
	320	108	4.0	22330	22330K	850	1100	1000.0	1030.0	43.000
160	290	80	3.0	22232	22232K	900	1200	630.0	652.0	22.200
	340	114	4.0	22332	22332K	800	1000	1020.0	1050.0	51.000
170	310	86	4.0	22234	22234K	850	1100	705.0	745.0	29.000
	360	120	4.0	22334	22334K	750	950	1130.0	1220.0	60.000
180	320	86	4.0	22236	22236K	800	1000	720.0	785.0	30.000
	380	126	4.0	22336	22336K	700	900	1240.0	1340.0	70.000
190	340	92	4.0	22238	22238K	750	950	802.0	858.0	35.300
	400	132	5.0	22338	22338K	670	850	1360.0	1480.0	81.000
200	380	98	4.0	22240	22240K	700	900	902.0	990.0	47.700
	420	138	5.0	22340	22340K	630	800	1460.0	1590.0	94.000